

General

EOCR-DS3 series overload and phase lost, reverse phase relays are designed to prevent the failures originated from motor heat..

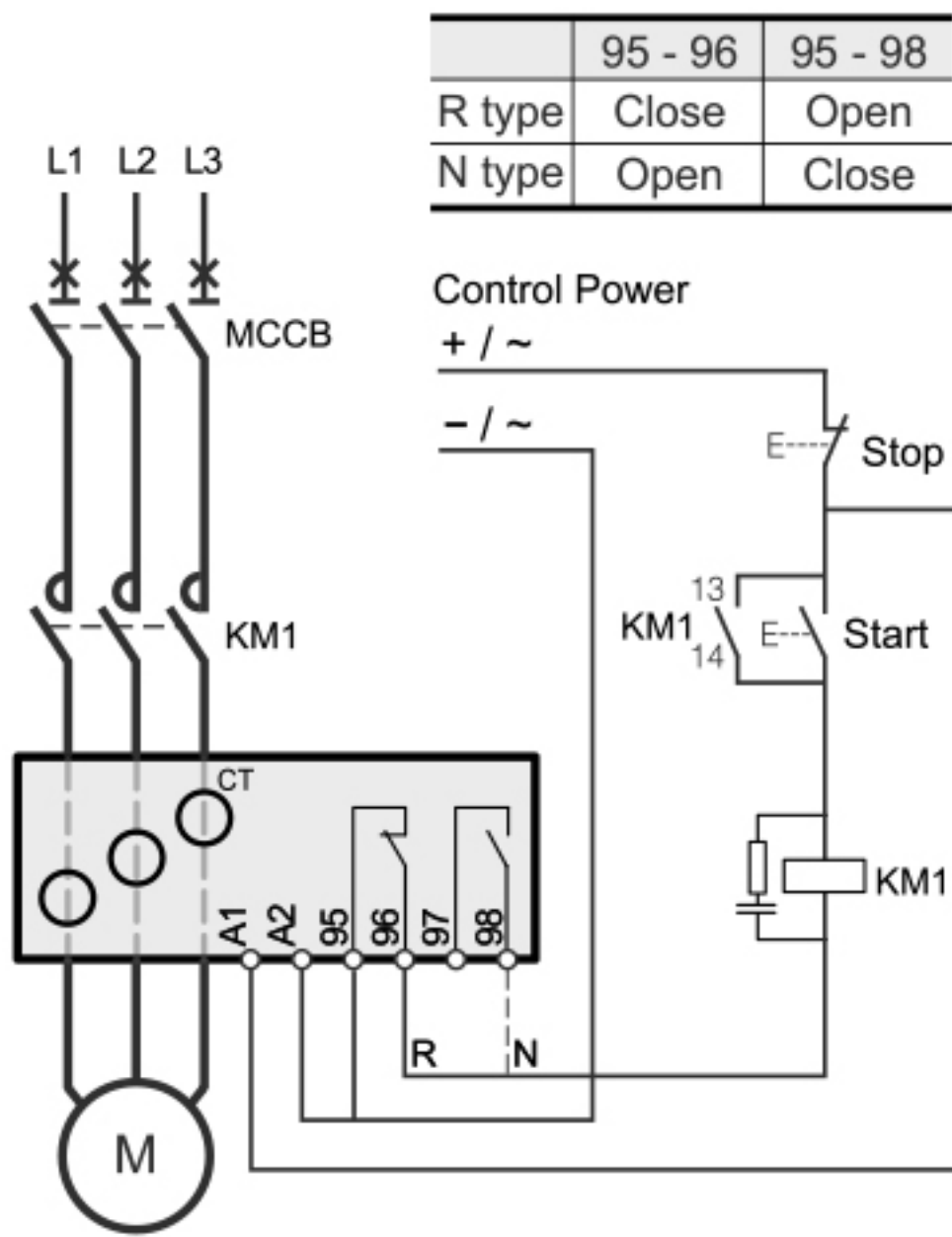

	95 - 96	95 - 98
R type	Close	Open
N type	Open	Close

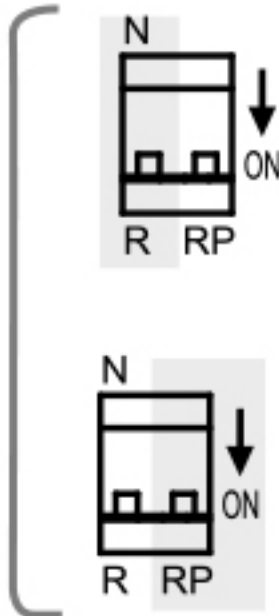

NVR (No Volt Release) / N:Fail safe, R:No Fail safe

To change setting parameters, turn the control power off and turn it on again, or press Reset button for initialization.

RP : — / Reverse phase detection

Reverse phase detection will be activated or deactivated as soon as the switch changes.

※ PL : The phase-loss function can be activated/deactivated by a sequence with the two push buttons. With the Reset button pressed at least 5 second, both of the two LEDs become blinking or ON.

	PWR(Green)	TRIP(Red)
PL ON	On	On
PL Off	Blink	Blink

Connection diagram for EOCR-DS3

Usage of Relay and working principle

- 1) When commissioning, set start delay time (D-Time knob) to know motor run-up time, or to the maximum, if not known.
- 2) Set trip delay time (O-Time knob) to desired trip time.
- 3) Set load currents (LOAD knob) at the rated full load or desired currents.
- 4) With connections made and control power on, depress TEST button and hold. Verify the red LED illuminates and the internal relay should switch contacts after the sum of D-Time and O-Time. Depress RESET button.
- 5) Start the motor and notice run-up time. Then, slowly turn the LOAD knob counter clockwise, until the LED flashes, where the 100% of the actual load currents is indicated. Set the LOAD knob to the desired trip currents. 110%~125% setting of running current is recommended.
- 6) Reset D-Time knob setting to normal run-up time.

Maintenance

Periodic testing of TEST button is recommended to ensure the full protection and regularly as a preventive maintenance

Warnings

Authorized technical engineers only for installation, maintenance or repair. Adjust the settings according to the electric characteristics of a motor, an inappropriate setting may cause permanent damage on the motor. External filter should be installed to reduce harmonics in an environment where the AC power contains excessive harmonic than IEC standard. No installation in the site may result in accuracy problem, abnormal operation and mal-function.

LED Indication	EOCR-DS3	
	PWR(Green)	TRIP(Red)
Starting	Blink	Blink
Normal operation	On	Off
Over-current	On	Blink
Trip	Off	On
Stall	Off	Blink
Phase Loss(PL)	L1	Off
	L2	Off
	L3	Off
Reverse Phase(RP)		

Dimensions for EOCR-DS3

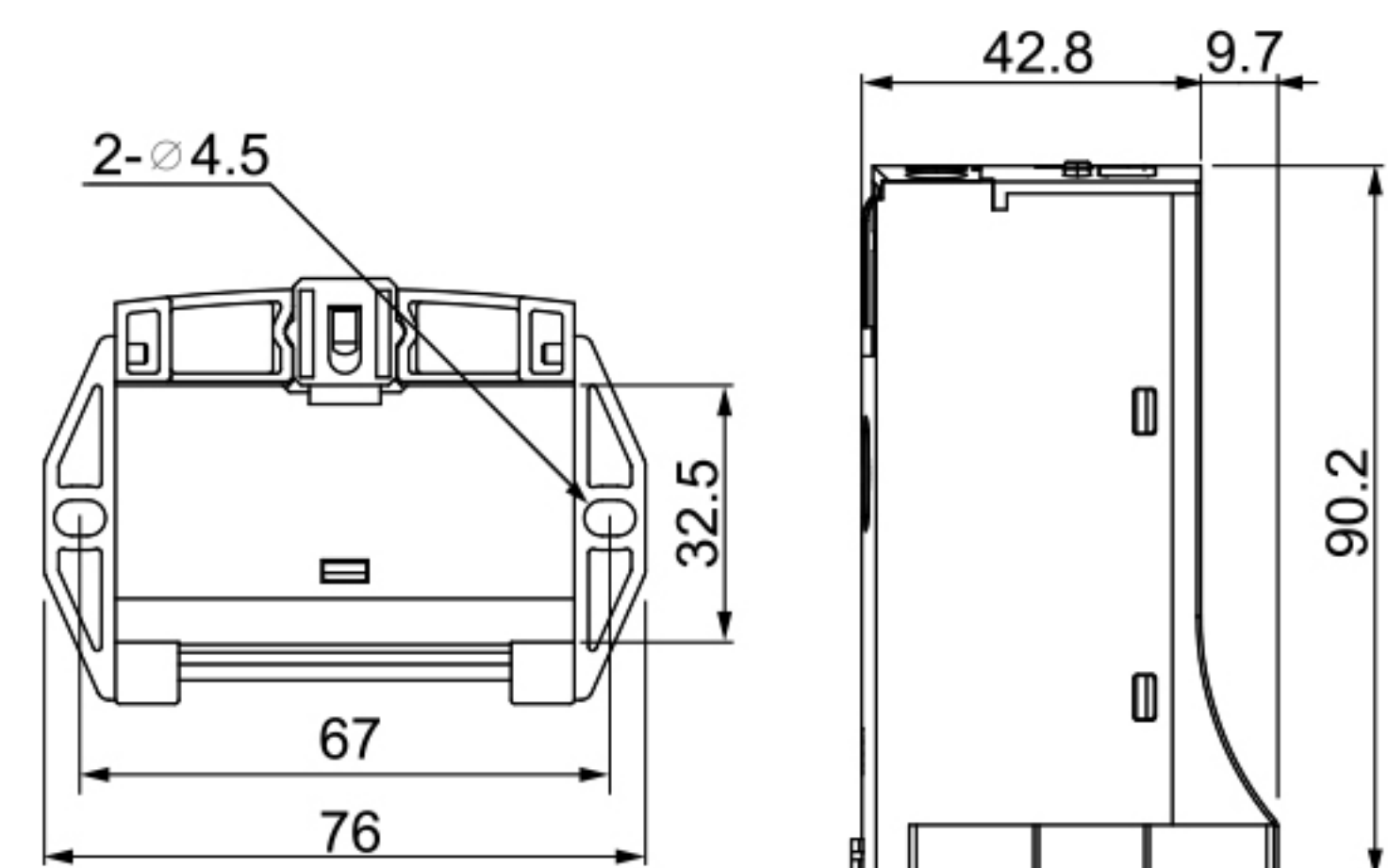
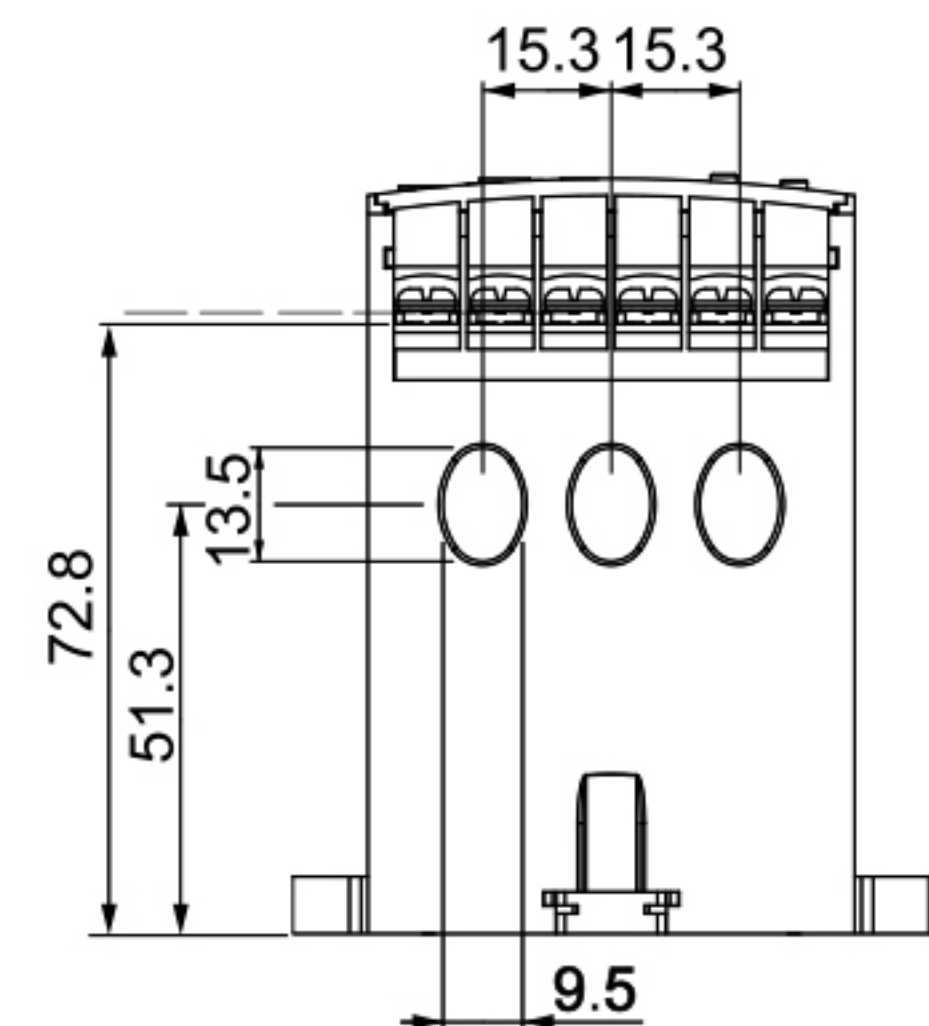

DIN Rail & MOUNTING HOLE SIZE

Technical Specifications:

- Current Range::TYPE05) 0.5-6A, TYPE30) 3-30A, TYPE60) 5-60A
- Operating Voltage (Un):24-240VAC/DC
- Operating Frequency.....:50/60Hz
- Operating Power.....:<2W
- Operating Temperature.....:-20°C.....+55°C
- Waiting(t).....:D-Time 0.2-30s, O-Time 0.2-10s
- Asymmetry Set.....:%±10
- Contact.....:5A 250V AC Resistive Load
- Connection Diagrams.....:35mm Din Rail (D) or Pane (P)