

General

Voltage control relays are designed to protect devices with sensitive operating voltage values from faults that may be caused by mains voltage.

Device Usage and Working Principle

Make the connections of the device in accordance with connection scheme. Set the required settings of the device according to the operating voltage values of the load. When the device is energized, if the voltage values are normal according to the set values, the relay gets activated and the relay LED (◻) is turned on. (In the case of models with phase sequence control, the phase sequence must also be correct.) When the voltage values go out of the set values, the related fault LED is on, it waits until the delay time (DT), after the time has elapsed, the relay gets de-activated and the relay LED goes out. When the voltages return to their normal values, the device waits until the reset time (RT), after the time has elapsed the relay gets activated and the relay LED is turned on.

The **High Voltage Protection** function is deactivated when the HV control knob is set to **Off**.
The **Low Voltage Protection** function is deactivated when the LV control knob is set to **Off**.

Relay is Activated: 2 (COM) and 3 (NC) short circuit, 1 (NC) and 2 (COM) open circuit.
Relay is De-activated: 2 (COM) and 1 (NC) short circuit, 3 (NC) and 2 (COM) open circuit.

Required Settings and Error Notifications

HV: High Voltage Set Value, when the voltage rises above this value, HV LED is on.
LV: Low Voltage Set Value, when the voltage drops below this value, LV LED is on.
DT: Delay Time, is the time to wait before entering the fault.
RT: Reset Time, is the time to wait for the relay to pull when the voltages return to normal.

Led Notifications By Errors

Error	LV LED	HV LED	⚡ LED	⚡ LED
No error. Phase sequence and voltages are normal.	◻	◻	◻	◻
It counting the delay time for low voltage error.	◼	◻	◻	◼
Low voltage error.	◼	◻	◻	◻
It counting the delay time for high voltage error.	◻	◼	◻	◼
High voltage error.	◻	◼	◻	◻
It counting the delay time for high & low voltage error.	◼	◼	◻	◼
High & low voltage error.	◼	◼	◻	◻
High voltage fuse protection.	◻	◼◼	◻	◻
Low voltage fuse protection.	◼◼	◻	◻	◻
Phase sequence and fault of phase absence.	◻	◻	◼	◻
Inadequate supply voltage error.	◼◼	◼◼	◻	◻

LED is Off : ◻ LED is On : ◼ LED is Flashing : ◼◼

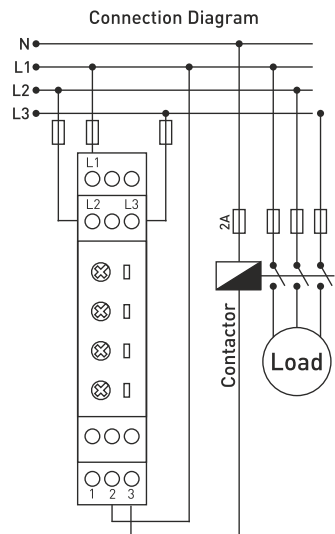
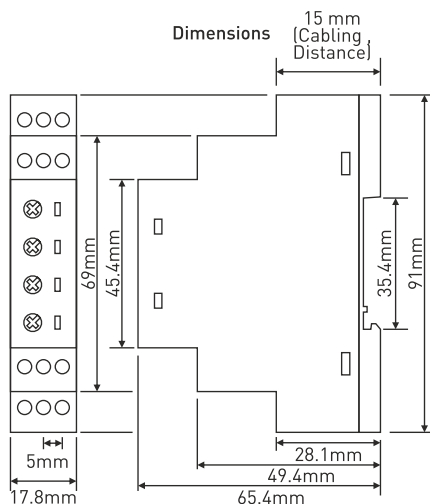

Tecnical Specifications

- Operating Volt. : 3x220V AC 50/60Hz.
- High Voltage : 230V-300V
- Low Voltage : 140V-210V
- Delay Time : 0,1 sec. - 20 sec.
- Reset Time : 0,1 sec. - 20 sec.
- Operating Power : <6VA
- Operating Temp. : -20°C.....+55°C
- Display : 4x LEDs
- Connection Type : Assembled on the din rail.
- Weight : 0,210 kg.
- Contact : 5A 250VAC Resistive Load
- Operating Altitude : <2000m
- Cable Diameter : 1,5mm²

Protection Functions

- High Voltage Protection - To enter the error state:** If one or more of the phases goes above the high voltage set value, the HV LED is on, the device waits until the set delay time (DT), after the time has elapsed the relay gets de-activated and the relay LED is off.
- High Voltage Protection - Exiting the error state:** When all phases drops below by 3% of the high-voltage set value, the device waits for the reset time (RT). After the time passes, the HV LED is off, the relay gets de-activated and the relay LED is on.
- High Voltage Fuse Protection - To enter the error state:** If one or more of the phases exceeds 1.5 times the rated operating voltage, the HV LED is flashes, after 100 milliseconds the device gets deactivated the relay, and the relay LED is turned off.
- High Voltage Fuse Protection - Exiting the error state:** When all phases drops below by 3% of the high voltage set value, the device waits for the reset time (RT). After the time passes, the HV LED is off, the relay gets activated and the relay LED is on.
- Low Voltage Protection - To enter the error state:** If one or more of the phases goes below the low voltage set value, the LV LED is on, the device waits until the set delay time (DT), after the time has elapsed the relay gets de-activated and the relay LED is off.
- Low Voltage Protection - Exiting the error state:** When all phases goes above by 3% of the low voltage set value, the device waits for the reset time (RT). After the time passes, the LV LED is off, the relay gets activated and the relay LED is on.
- Low Voltage Fuse Protection - To enter the error state:** If one or more of the phases 0.5 times below the rated operating voltage, the LV LED is flashes, after 100 milliseconds the device gets deactivated the relay, and the relay LED is turned off.
- Low Voltage Fuse Protection - Exiting the error state:** When all phases goes above by 3% of the high voltage set value, the device waits for the reset time (RT). After the time passes, the LV LED is off, the relay gets activated and the relay LED is on.
- Inadequate Supply Voltage Protection - To enter the error state:** LV and HV LEDs flashes when N-L1 voltage for is lower than the nominal operating voltage by 0.4 times, after 100 millisecond the device gets deactivated the relay, and relay LED is turned off.
- Inadequate Supply Voltage Protection - Exiting the error state:** When N-L1 voltage values goes above by 3% of the low voltage set value, the device waits until the reset time (RT), after the time has elapsed, the LV and HV LEDs turn off, the relay gets activated and relay LED is on.
- Phase Sequence Protection:** If the phase sequence of the device is reversed, the phase sequence error LED (⚡) will light up and the relay will not gets activated (only in GKV-15F).
- Phase Absence Protection:** If one of the phases is not connected to the device, the phase absence error LED (⚡) flashes (only in GKV-15). It is also a phase sequence error for phase sequence model.

Maintenance

Switch off the device and release from connections. Clean the trunk of device with a swab. Don't use any conductor or chemical might damage the device. Make sure device works after cleaning.

Warnings

- Please use the device according to the manual.
- Don't use the device in wet.
- Include a switch and circuit breaker in the assembly.
- Put the switch and circuit breaker nearby the device, operator can reach easily.
- Mark the switch and circuit breaker as releasing connection for device.

