

General

VR voltage protection relay is designed to protect devices with sensitive operating voltage values from errors that may arise from mains voltage.

Device Usage and Principle of Operation

Make the connections of the device according to the connection type. Otherwise, the device may be damaged. Adjust the high & low voltage settings of the according to the voltage values of the you will use.

Voltage Error state: If the mains (input) voltage value is between the high and Low voltage set values (when the device is not in error), the mains (input) voltage value rises above the high voltage set value or under below the low voltage set value; the device waits for the set error waiting time, then the device de-energizes the relay, the error led turn on, the mains (input) voltage value displayed on the voltage display flashes throughout the error period.

Exit voltage error state: When the mains (input) voltage value returns to normal / when the reaches a value between the high and Low voltage set values the device waits for the set reset waiting time, then the device energizes the relay, the error led turns off, the out led turns on.

Display and Buttons

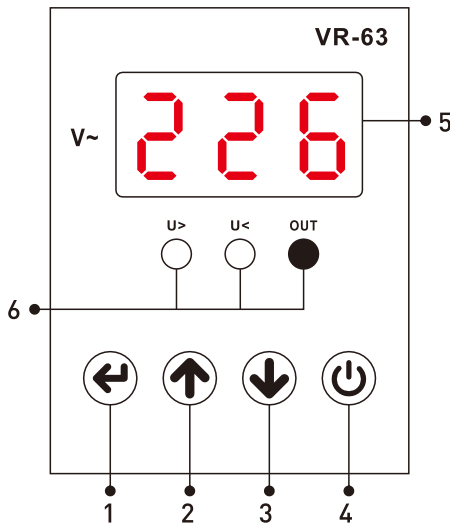

1 - SET Button: This button is used to save after setting/changing high/low voltage setting values and error wait time.

2-UP Button: Increase the required value.

3- Down Button: Reduce the required value.

4-Manual On/Off Button: For close the device output. In this state, the screen will display "off" and the device cannot be automatic reset. Press this button again to Switch on the device intouse again (No failure premise).

5-Voltage Display

1 St Display Group: During normal operation, current value is displayed here, the screen lights up steadily when not in error state, the display flashes in case of error [overload]. During the programming process, the numeric value of the relevant program is displayed here.

6- LEDs:

V>: Light up when an high voltage fault occurs.

V<: Light up when an low voltage fault occurs.

Out: Lights up when the device starts to output.

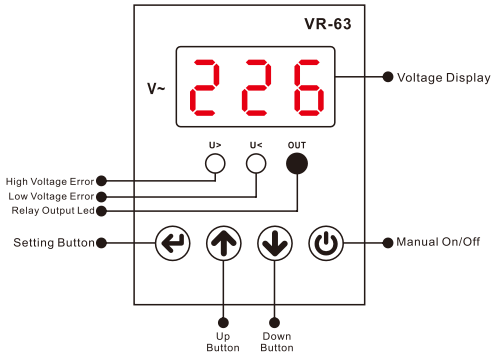

Dimensions

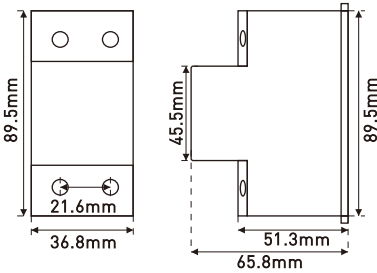

Connection Diagram

The neutral an phase conncticon comes from the mains must be connected to the "N" and "L" terminals at the IN part of the device. Neutral and Phase connection of the devices that are desired to be protected from over and under voltage should be taken from the "N" and "L" terminals in the OUT part of the device.

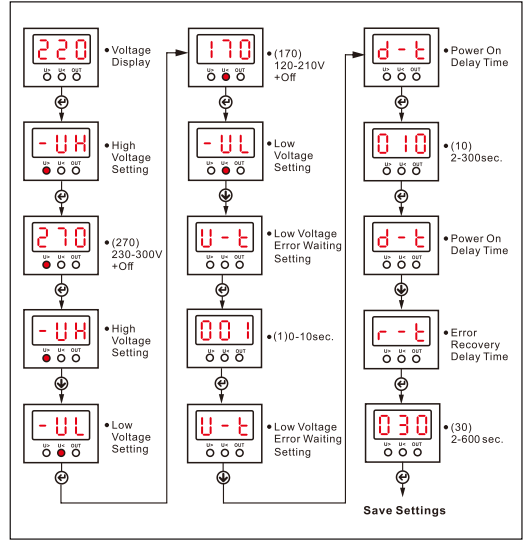
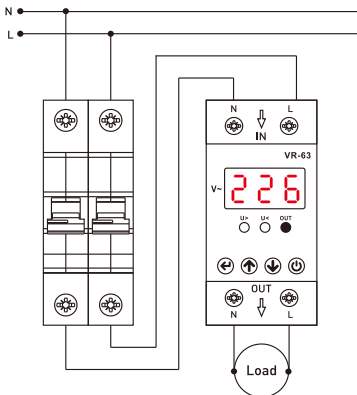

Technical Informations

Technical Specifications	
Rated Current	40A Or 63A
Rated Voltage	220V AC
Frequency	50Hz. - 60Hz.
Protection Range	0V - 450V AC
Operating Temp.	-20°C - +55°C
Operating Power	<4VA
Operating Altitude	<2000m
Display	1x3 Digit LED Display 3 LEDs
Weight	63A)<153gr.
Setting Ranges	
High Voltage	230 - 300+Off
Low Voltage	120 - 210+Off
Low Voltage Fuse	115V(Fixed)
High Voltage Time	0.1sec.(Fixed)
Low Voltage Time	0 - 10sec.
Power on Delay Time	2 - 300sec.
Reset Time	2 - 600sec.



※Manual Button: Can only be operated when there is no fault