

HP54

SL 3.1

4 step ventilation + thermoreg.

Handbook

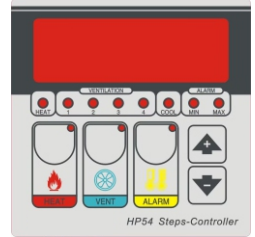

MAIN SETTINGS (Run Mode)

HEAT TEMPERATURE SETTING.



Press HEAT:

This message will be displayed of the Set Heat temperature value

Press + or - to modify, press HEAT to exit.

HEAT

VENTILATION TEMPERATURE SETTING



Press VENT:

This message will be displayed is of the set Ventilation temperature value (start first step)
Press + or - to modify, press VENT to confirm.

VENT

At this point: This message is displayed, representing the minimum ventilation step (*).

Press + or - to modify, press VENT to confirm.

SP. _ _

At this point: This message is displayed, representing the maximum ventilation step (*).

Press + or - to modify, press VENT to confirm.

SP. _ _

If the minimum speed is set to 0, this message displayed is of the Set Shutter Running Time (seconds).

Press + or - to modify, press VENT to confirm.

ton

At this point: this message will be displayed of the Shutter Dwell Time (sec.)

Press + or - to modify, press VENT to confirm.

toF

At this point: this message will be displayed of the shut ventilation speed number

Press + or - to modify, press VENT to exit.

SP. _ _

ALARM PARAMETER SETTING.



Press ALARM:

This message will be displayed of the Set Minimum Alarm temperature value.
Press + or - to modify, press ALARM to confirm.

AL. _ _

At this point: this message will be displayed of the set Maximum Alarm temperature value .

Press + or - to modify, press ALARM to exit.

AL. _ _

VIEWING TEMPERATURE RECORDING

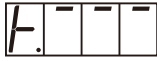

Press + :  will be displayed followed by °Maximum Temperature Recording.



Press - :  will be displayed followed by °Minimum Temperature Recording.

Values recorder are memory permanent stored: for memory clear keep pushed + keys for more than 3 seconds: **CLEA** message will be composed on display before clearing operation.

COST PROGRAMMING (System constants)



These settings refer to the operation mode of the system and must be made on initial startup. Press - / + at the same time for at least one second: the message **C.O.S.t.** will be displayed. Press than repeatedly **ALARM** until the message regarding the chosen variable is displayed (see table below): variable's value and message will be displayed.

Press + or - to set a new value and then press **ALARM** to confirm.

The next system constant will then appear.

You can press **ALARM** for at least 2 seconds to exit and return to the Run Mode.

Mess.	Valore	Meaning	Note
d.HEA	0.2 °	°HEAT differential	1
rEL.1	0.0 °	° Temperature set of step 1 referred to the vEnt set	1
rEL.2	1.0 °	° Temperature set of step 2 referred to the Step 1 start	1
rEL.3	1.0 °	° Temperature set of step 3 referred to the Step 1 start	1
rEL.4	1.0 °	° Temperature set of step 4 referred to the Step 1 start	1
d.FAn	0.2 °	° Ventilation differential	1
r.COL	6.0 °	° COOL setting shift referring to vEnt set	1
d.COL	0.2 °	° COOL differential	1
tEnP	=1	Temperature unit (=1: °C, =2: °F)	
Ad.tE	0.0 °	° Temperature sensor adjustment (+ or -)	2
tYPE	1	Start ventilation actioning mode	3

1) For more details see Operative Diagrams

2) You can correct the readings on the sensor (+ or -).

3) Different mode of ventilator initial start-up optionally settable (step from 0 to 1 speed).

tYPE= 1 : 0 to 1 step become in normal mode.

tYPE= 2 : 0 to 1 step become with a momentary 10 seconds at speed 2.

tYPE= 3 : 0 to 1 step become with a momentary 5 seconds at speed 3.

tYPE= 4 : 0 to 1 step become with a momentary 5 seconds at speed 4.

tYPE=13 : Heating mode ventilation.

tYPE=14 : Progressive ventilation contacts (On-Off regulation type).

Options 2, 3, 4 permits to make an easy opening of shutter models ventilators.

Option 13 permits Heater mode ventilation (low temperature = high speed; in other options high temperature= high speed).

Option 14 permits On-Off regulation mode (in other condition regulation is for variable speed control).

PRESET PROGRAMS (bootstrap)



This processor is already programmed with the following (variable) settings.

To return to these settings at any time you may:

Power off the processor, press **MAX VENT** key and keep it pressed giving power on: **boot** message will be displayed (release now **MAX VENT** key).

HEAT = 20.0° vEnt = 25.0° SP._ = 0 SP.- = 4 AL._ = 10.0° AL.- = 40.0°

t.on = 10" t.oF = 60" SP.-- = 0

The **COST** values are shown in **COST** Promagramming.

MANUAL MODE



In some start-up conditions may be useful to work in "manual" mode:

Power off the processor, press + key and keep it pressed giving power on: **HAnd** message will be displayed (release now + key).

Push + until is displayed number required to be handed (see table State indication lamps) and push **ALARM** for activating relay.

Pushing again + for increase relay number previous relay is deactivated.

You can press **ALARM** key for a least two seconds to escape and return to the Run Mode.

OPERATIVE DIAGRAMS

If Minimum speed is programmed to 0 (SP._=0), when the ventilation is off it is possible to insert a cyclical operation of minimum speed, composed of a turn-on time fans (t.on), by a switch-off time fans (t.oF), and the selected speed during an's shuttering operation (SP- -).

With tYPE = 13 :

- V0 <> V4
- V1 <> V3
- V2 <> V2
- V3 <> V1
- V4 <> V0

Heater mode ventilation

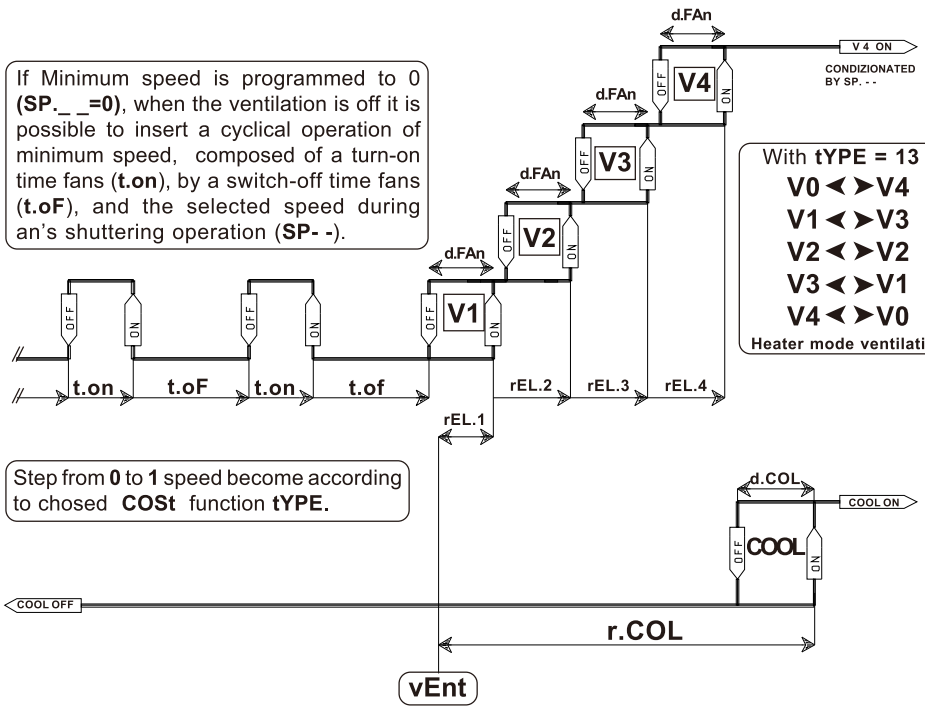

Step from 0 to 1 speed become according to chosed **COST** function tYPE.

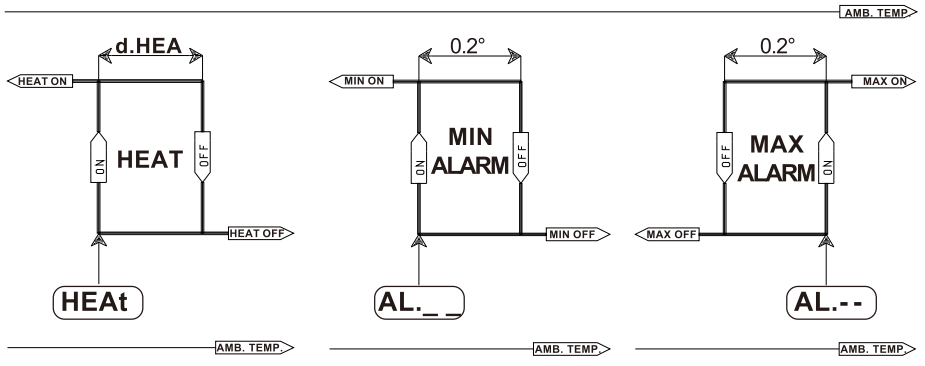

STATUS INDICATION LAMPS

The lights situated at the bottom of the display show the state of the relay.

Table of relay Outputs with tYPE= 1-2-3-4-13 (Variable speed control)

Lamp.	Output relay						N°Relay
	HEAT	0	1	2	3	4	
HEAT	1	0	0	0	0	0	5
VENT 1	0	0	1	0	0	0	1
VENT 2	0	0	0	1	0	0	2
VENT 3	0	0	0	0	1	0	3
VENT 4	0	0	0	0	0	1	4

Table of relay Outputs with tYPE = 14 (On-Off regulation type)

Lamp.	Output relays with tYPE = 14 (see COST)						N°Relay
	HEAT	0	1	2	3	4	
HEAT	1	0	0	0	0	0	5
VENT 1	0	0	1	0	0	0	1
VENT 2	0	0	1	1	0	0	2
VENT 3	0	0	1	1	1	0	3
VENT 4	0	0	1	1	1	1	4

INSTALLATION

How to connect the line

Connect 230V line on terminals L-N.

Protect supply with adequate fuse.

How to connect the sensors

Connect the provided sensor as shown in the diagram. **For remote connections use a standard 0.5-square millimeter two-pole wire**, taking great care over the connections, by insulating and sealing the joins carefully. **-O.C.-** is displayed when the temperature sensor wiring is open, **-S.C.-** is displayed when the temperature sensor wiring is short circuit.

How to connect the contacts

Output contacts are N.O. (Normally Opened free of voltage) on which is applicable a 4AMP AC1 maximum load.

3-4= Step 1 contact

3-5= Step 2 contact

3-6= Step 3 contact

3-7= Step 4 contact

11-12= Heat contact

12-13= Cool contact

Alarm and Cooling are available only with **HPAL** optional slot.

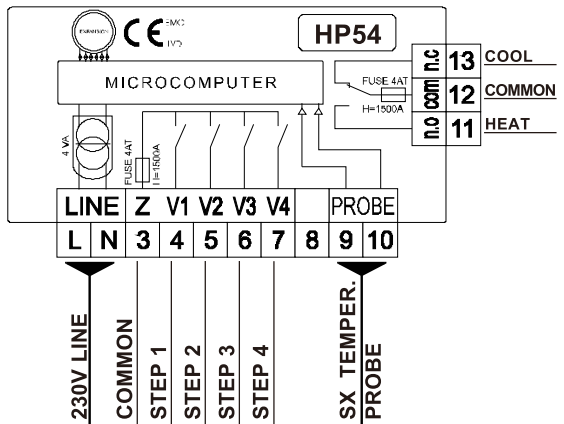

Other power voltage if you required